



Internal Use Only

<http://biz.lgservice.com>

# LG Air Conditioner

## SVC MANUAL(Exploded View)

**MODEL : A3UW216FA5**  
**MU3M21[UE0]**

### **CAUTION**

Before Servicing the unit, read the safety precautions in General SVC manual.  
Only for authorized service personnel.

# 1. Specification

Outdoor Unit			A3UW216FA5 / MU3M21[UE0]
Nominal Capacity (Min~Rated~Max)	Cooling	kW	1.85~6.15~7.33
		Btu/h	6,300~21,000~25,000
	Heating	kW	2.22~7.03~7.77
		Btu/h	7,560~24,000~26,500
Nominal Input (Min~Rated~Max)	Cooling	kW	0.72~1.53~2.94
	Heating	kW	0.88~1.63~2.95
Energy label			A/A
Testing Combination			CS07AQ NB0*3EA
Running Current	Cooling	A	3.1~6.65~12.7
	Heating	A	3.8~7.1~12.8
Starting Current	(Cooling/Heating)	A	-
Power Supply		Ø / V / Hz	1 / 220~240 / 50
Power Supply Cable (outdoor)		No.x mm <sup>2</sup>	3 * 2.5
Power and transmission cable (outdoor to indoor)		No.x mm <sup>2</sup>	4 x 0.75 (Including Earth)
Dimensions	W*H*D	mm(inch)	870 * 808 * 320(34.3 * 31.8 * 12.6)
Net Weight		kg(lbs)	61(134)
Max. Number of Connectable Indoor Units			3
Compressor (Inverter)	Type		Twin-Rotary
	Qty x Model		GJT240D
	Motor Type		BLDC
	Oil Charge volume	cc	900
	Oil Type		FVC68D
Refrigerant	Charge (at 7.5m)	g(oz)	2,300(81.13)
	Type		R410A
	Control		EEV
Heat Exchanger	Rows x Column x FPI		2R * 36C * 18
Defrosting Method			Reversing cycle
Fan	Capacitor	µF/Vac	-
	Drive		DC
	Discharge direction	Side / Top	Side
	Air Flow Rate	CMM(CFM)	53 (1872)
Noise Level(H)	Sound Pressure at 1m	dB(A)±3	52
Piping connections	Liquid(Ø)	mm(inch)	6.35 (1/4) * 3EA
	Gas(Ø)	mm(inch)	9.52 (3/8) * 3EA
Max. Interunit Piping Length	Total of Each Room	m	50
	For One Room	m	25
Max. Elevation	Indoor Unit~Outdoor Unit	m	15
	Indoor Unit~Indoor Unit	m	7.5

## Note:

### 1. Capacities are based on the following conditions:

- Cooling: - Indoor Temperature 27°C(80.6°F) DB/19°C(66.2°F) WB
- Outdoor Temperature 35°C(95°F) DB/24°C(75.2°F) WB
- Heating: - Indoor Temperature 20°C(68°F) DB/15°C(59°F) WB
- Outdoor Temperature 7°C(44.6°F) DB/6°C(42.8°F) WB
- Piping Length - Interconnecting Piping Length 7.5m
- Level Difference of Zero

- 2. Wiring cable size must comply with the applicable local and national code.
- 3. The specification may be subject to change without prior notice for purpose of improvement.

## 2. Function Table

Category	Function	A3UW216FA5 / MU3M21[UE0]
Reliability	Defrost / Deicing	O
	High pressure switch	X
	Low pressure switch	O
	Phase protection	X
	Restart delay (3-minutes)	O
	Self diagnosis	O
	Soft start	O
	Test function	O
Convenience	Auto operation(Artificial intelligence)	O
	Auto restart operation	O
CAC network function	Network solution(LGAP)	O
	PDI(Power Distribution Indicator)	PQNUD1S00
	PI485	PMNFP14A0
Special function kit	Low ambient operation	X
Others	Thermistor	-

**Note :**

O : Applied X : Not applied - : No relation

Option : Model name & price are different according to options, and assembled in factory with main unit.

Accessory : Installed at field, ordered and purchased separately by the corresponding model name, supplied with separate package

★ : These safty switcher are standard or optional features defending on region & country

### 3. Piping Diagrams

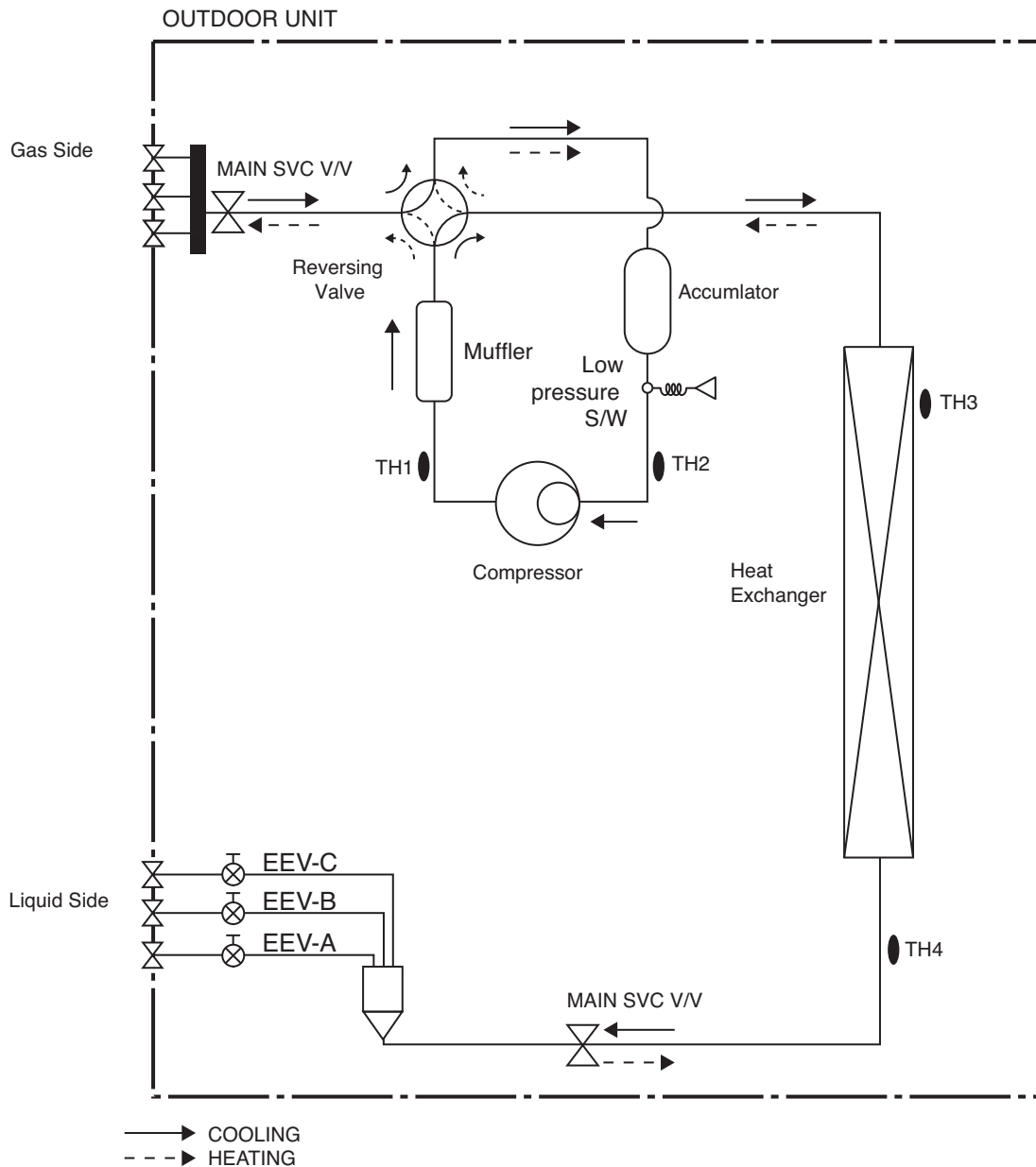

**Note:**

COMP: Compressor(Inverter)

Acc: Accumulator

EEV: Electronic Expansion Valve

LOC.	Description	PCB Connector
Th1	Thermistor for discharge pipe temperature	CN_TH3
Th2	Thermistor for suction pipe temperature	CN_TH3
Th3	Thermistor for outdoor air temperature	CN_TH2
Th4	Thermistor for condensing temperature	CN_TH2

# 4. Wiring Diagrams

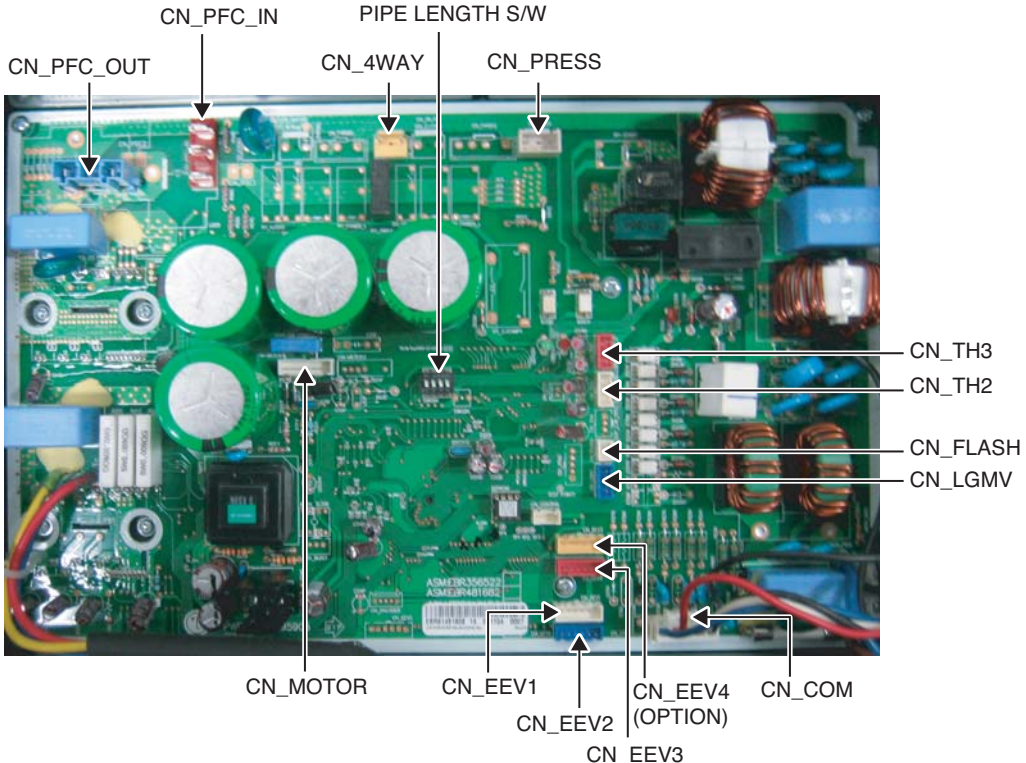
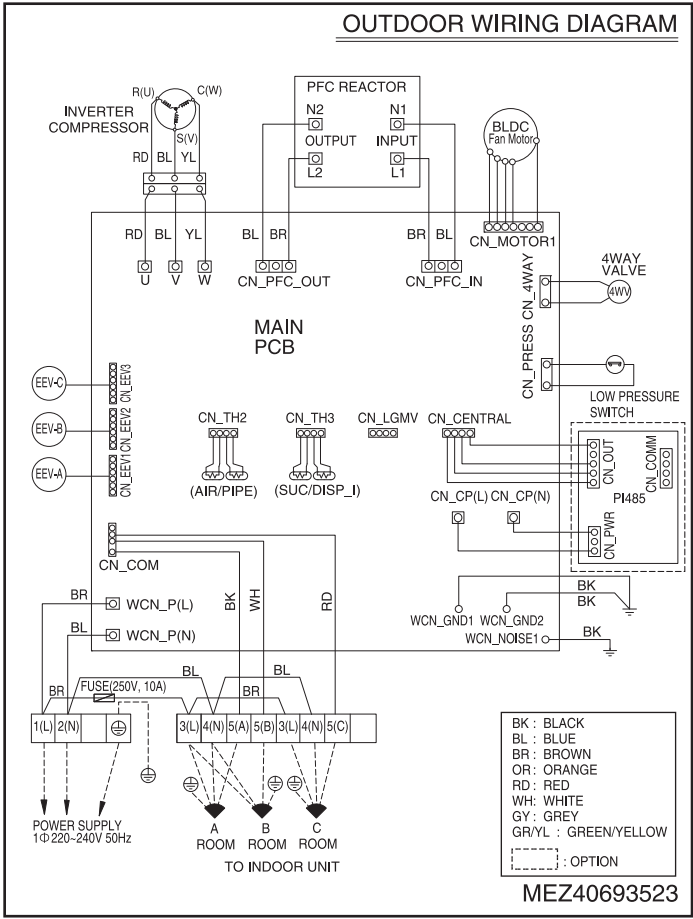

# 5. Schematic Diagram

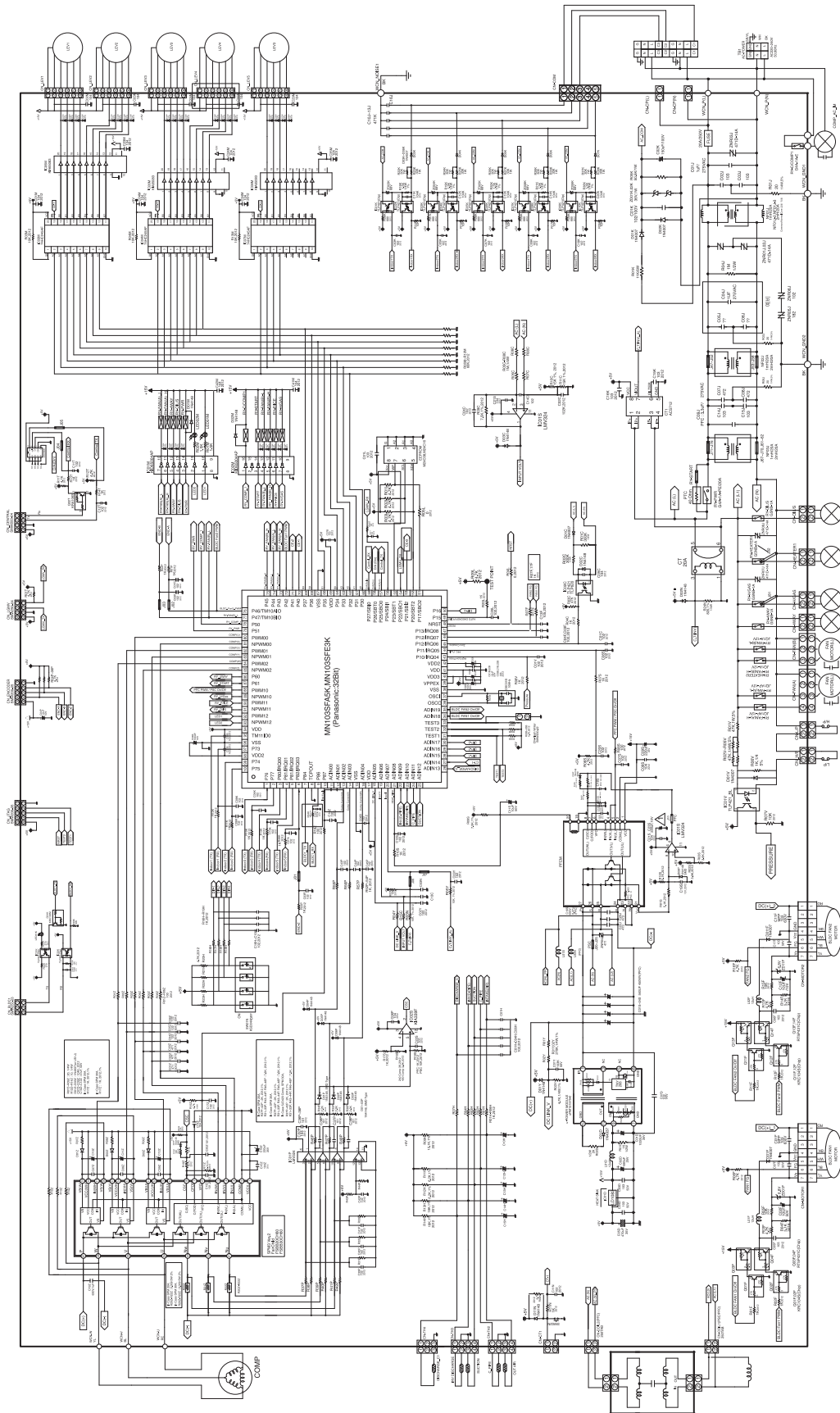

# 6. Exploded View

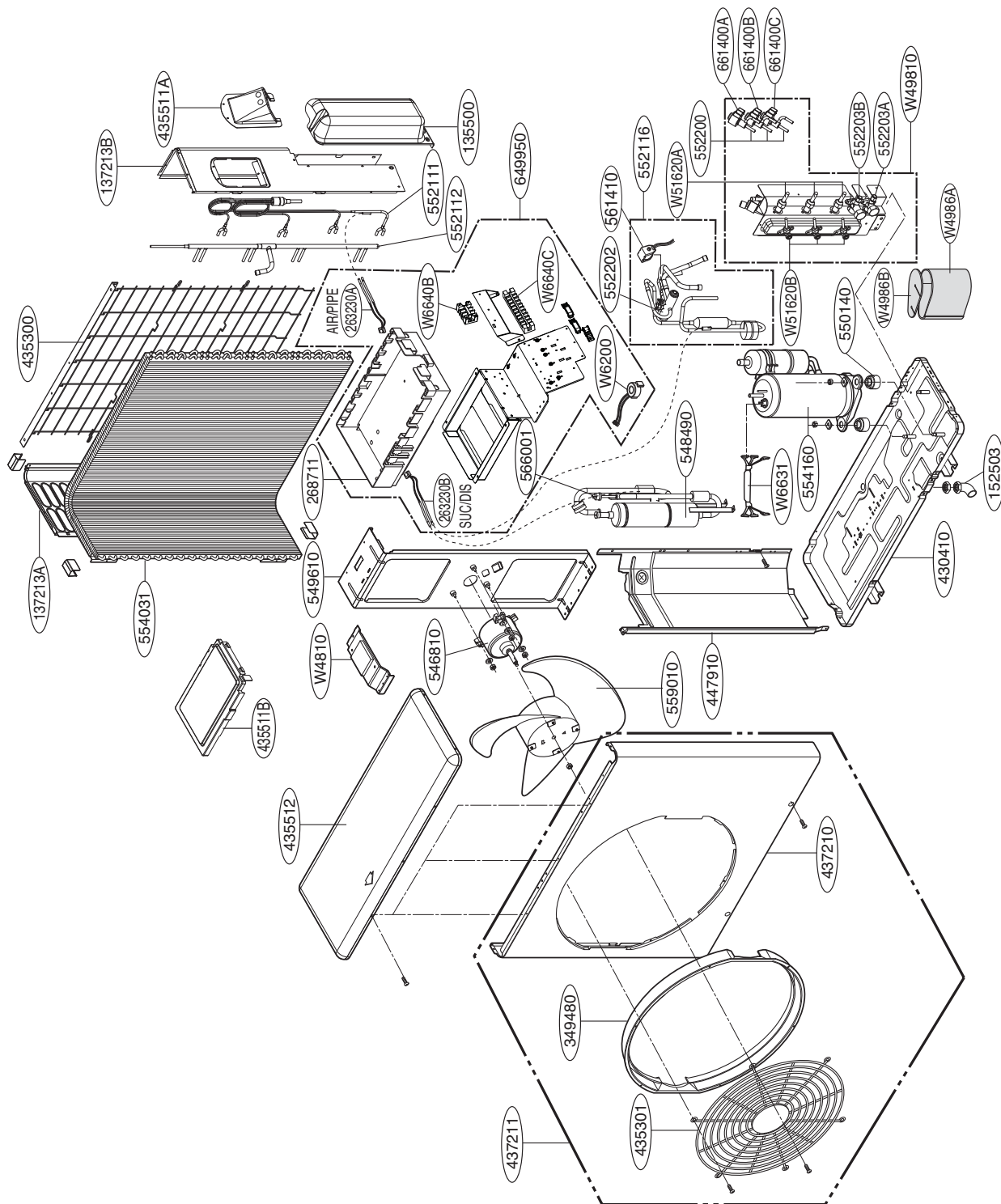

Model	Classification	Description	Part Number	Location Number	Remark
A3UW216FA5 (MU3M21[UE0])	Heating	Compressor	TBZ35296001	554160	-
		Harness, Multi	EAD41346203	W6631	

**NOTE**

\* Please ensure GCSC since the replacement parts may be changed depending upon the buyer's request. Please check the correct parts in View RPL(Replacement Part List) on GCSC. (GCSC Website <http://biz.Lgservice.com>)



P/NO : MFL61921708

APRIL, 2016